

FIFTH EDITION

Fundamentals of Electric Circuits

**INSTRUCTOR
SOLUTIONS
MANUAL**



Charles K. Alexander | Matthew N. O. Sadiku

Review Questions

- 1.1** One millivolt is one millionth of a volt.
(a) True (b) False
- 1.2** The prefix *micro* stands for:
(a) 10^6 (b) 10^3 (c) 10^{-3} (d) 10^{-6}
- 1.3** The voltage 2,000,000 V can be expressed in powers of 10 as:
(a) 2 mV (b) 2 kV (c) 2 MV (d) 2 GV
- 1.4** A charge of 2 C flowing past a given point each second is a current of 2 A.
(a) True (b) False
- 1.5** The unit of current is:
(a) coulomb (b) ampere
(c) volt (d) joule
- 1.6** Voltage is measured in:
(a) watts (b) amperes
(c) volts (d) joules per second
- 1.7** A 4-A current charging a dielectric material will accumulate a charge of 24 C after 6 s.
(a) True (b) False
- 1.8** The voltage across a 1.1-kW toaster that produces a current of 10 A is:
(a) 11 kV (b) 1100 V (c) 110 V (d) 11 V
- 1.9** Which of these is not an electrical quantity?
(a) charge (b) time (c) voltage
(d) current (e) power
- 1.10** The dependent source in Fig. 1.22 is:
(a) voltage-controlled current source
(b) voltage-controlled voltage source
(c) current-controlled voltage source
(d) current-controlled current source

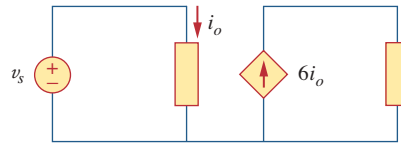

Figure 1.22

For Review Question 1.10.

Answers: 1.1b, 1.2d, 1.3c, 1.4a, 1.5b, 1.6c, 1.7a, 1.8c, 1.9b, 1.10d.

Problems

Section 1.3 Charge and Current

- 1.1** How many coulombs are represented by these amounts of electrons?
(a) 6.482×10^{17} (b) 1.24×10^{18}
(c) 2.46×10^{19} (d) 1.628×10^{20}
- 1.2** Determine the current flowing through an element if the charge flow is given by
(a) $q(t) = (3t + 8)$ mC
(b) $q(t) = (8t^2 + 4t - 2)$ C
(c) $q(t) = (3e^{-t} - 5e^{-2t})$ nC
(d) $q(t) = 10 \sin 120\pi t$ pC
(e) $q(t) = 20e^{-4t} \cos 50t$ μ C
- 1.3** Find the charge $q(t)$ flowing through a device if the current is:
(a) $i(t) = 3$ A, $q(0) = 1$ C
(b) $i(t) = (2t + 5)$ mA, $q(0) = 0$
(c) $i(t) = 20 \cos(10t + \pi/6)$ μ A, $q(0) = 2$ μ C
(d) $i(t) = 10e^{-30t} \sin 40t$ A, $q(0) = 0$
- 1.4** A current of 7.4 A flows through a conductor. Calculate how much charge passes through any cross-section of the conductor in 20 s.
- 1.5** Determine the total charge transferred over the time interval of $0 \leq t \leq 10$ s when $i(t) = \frac{1}{2}t$ A.
- 1.6** The charge entering a certain element is shown in Fig. 1.23. Find the current at:
(a) $t = 1$ ms (b) $t = 6$ ms (c) $t = 10$ ms

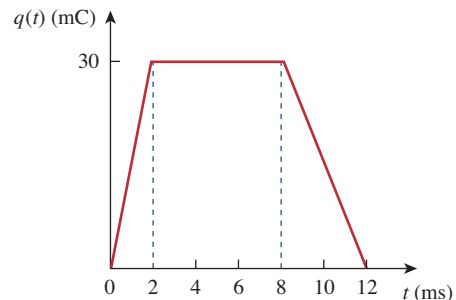

Figure 1.23

For Prob. 1.6.

- 1.7 The charge flowing in a wire is plotted in Fig. 1.24. Sketch the corresponding current.

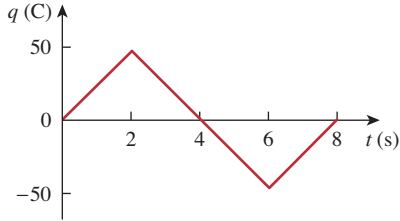

Figure 1.24

For Prob. 1.7.

- 1.8 The current flowing past a point in a device is shown in Fig. 1.25. Calculate the total charge through the point.

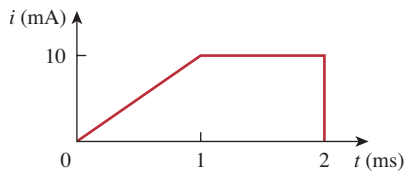

Figure 1.25

For Prob. 1.8.

- 1.9 The current through an element is shown in Fig. 1.26. Determine the total charge that passed through the element at:

- (a) $t = 1$ s (b) $t = 3$ s (c) $t = 5$ s

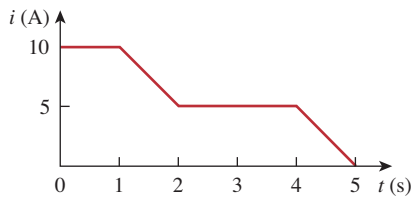

Figure 1.26

For Prob. 1.9.

Sections 1.4 and 1.5 Voltage, Power, and Energy

- 1.10 A lightning bolt with 10 kA strikes an object for 15 μ s. How much charge is deposited on the object?
- 1.11 A rechargeable flashlight battery is capable of delivering 90 mA for about 12 h. How much charge can it release at that rate? If its terminal voltage is 1.5 V, how much energy can the battery deliver?
- 1.12 If the current flowing through an element is given by

$$i(t) = \begin{cases} 3t \text{ A}, & 0 \leq t < 6 \text{ s} \\ 18 \text{ A}, & 6 \leq t < 10 \text{ s} \\ -12 \text{ A}, & 10 \leq t < 15 \text{ s} \\ 0, & t \geq 15 \text{ s} \end{cases}$$

Plot the charge stored in the element over $0 < t < 20$ s.

- 1.13 The charge entering the positive terminal of an element is

$$q = 5 \sin 4\pi t \text{ mC}$$

while the voltage across the element (plus to minus) is

$$v = 3 \cos 4\pi t \text{ V}$$

- (a) Find the power delivered to the element at $t = 0.3$ s.
- (b) Calculate the energy delivered to the element between 0 and 0.6 s.

- 1.14 The voltage v across a device and the current i through it are

$$v(t) = 10 \cos 2t \text{ V}, \quad i(t) = 20(1 - e^{-0.5t}) \text{ mA}$$

Calculate:

- (a) the total charge in the device at $t = 1$ s
- (b) the power consumed by the device at $t = 1$ s.

- 1.15 The current entering the positive terminal of a device is $i(t) = 6e^{-2t}$ mA and the voltage across the device is $v(t) = 10di/dt$ V.

- (a) Find the charge delivered to the device between $t = 0$ and $t = 2$ s.
- (b) Calculate the power absorbed.
- (c) Determine the energy absorbed in 3 s.

Section 1.6 Circuit Elements

- 1.16 Figure 1.27 shows the current through and the voltage across an element.

- (a) Sketch the power delivered to the element for $t > 0$.
- (b) Find the total energy absorbed by the element for the period of $0 < t < 4$ s.

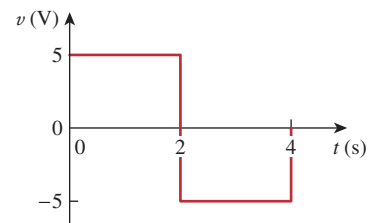
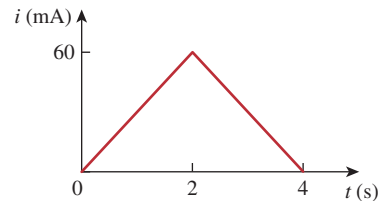

Figure 1.27

For Prob. 1.16.

- 1.17** Figure 1.28 shows a circuit with five elements. If $p_1 = -205 \text{ W}$, $p_2 = 60 \text{ W}$, $p_4 = 45 \text{ W}$, $p_5 = 30 \text{ W}$, calculate the power p_3 received or delivered by element 3.

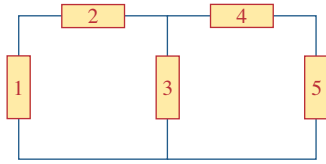

Figure 1.28

For Prob. 1.17.

- 1.18** Find the power absorbed by each of the elements in Fig. 1.29.

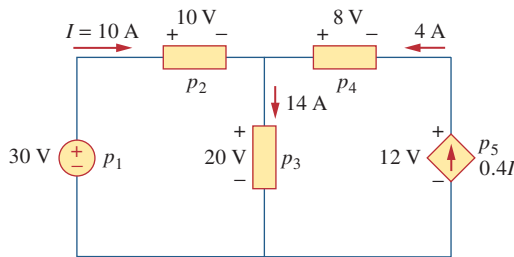

Figure 1.29

For Prob. 1.18.

- 1.19** Find I and the power absorbed by each element in the network of Fig. 1.30.

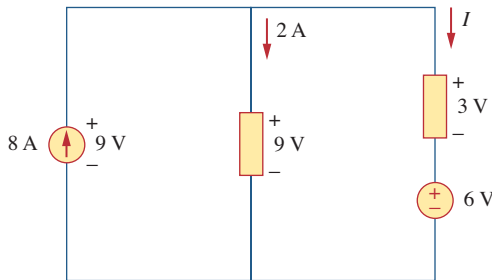

Figure 1.30

For Prob. 1.19.

- 1.20** Find V_o and the power absorbed by each element in the circuit of Fig. 1.31.

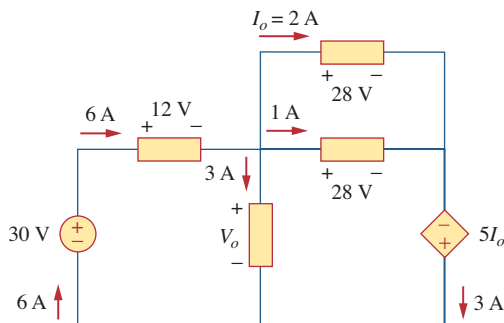

Figure 1.31

For Prob. 1.20.

Section 1.7 Applications

- 1.21** A 60-W incandescent bulb operates at 120 V. How many electrons and coulombs flow through the bulb in one day?

- 1.22** A lightning bolt strikes an airplane with 40 kA for 1.7 ms. How many coulombs of charge are deposited on the plane?

- 1.23** A 1.8-kW electric heater takes 15 min to boil a quantity of water. If this is done once a day and power costs 10 cents/kWh, what is the cost of its operation for 30 days?

- 1.24** A utility company charges 8.2 cents/kWh. If a consumer operates a 60-W light bulb continuously for one day, how much is the consumer charged?

- 1.25** A 1.5-kW toaster takes roughly 3.5 minutes to heat four slices of bread. Find the cost of operating the toaster once per day for 1 month (30 days). Assume energy costs 8.2 cents/kWh.

- 1.26** A flashlight battery has a rating of 0.8 ampere-hours (Ah) and a lifetime of 10 hours.

- (a) How much current can it deliver?
- (b) How much power can it give if its terminal voltage is 6 V?
- (c) How much energy is stored in the battery in Wh?

- 1.27** A constant current of 3 A for 4 hours is required to charge an automotive battery. If the terminal voltage is $10 + t/2 \text{ V}$, where t is in hours,

- (a) how much charge is transported as a result of the charging?
- (b) how much energy is expended?
- (c) how much does the charging cost? Assume electricity costs 9 cents/kWh.

- 1.28** A 60-W incandescent lamp is connected to a 120-V source and is left burning continuously in an otherwise dark staircase. Determine:

- (a) the current through the lamp.
- (b) the cost of operating the light for one non-leap year if electricity costs 9.5 cents per kWh.

- 1.29** An electric stove with four burners and an oven is used in preparing a meal as follows.

- Burner 1: 20 minutes
- Burner 2: 40 minutes
- Burner 3: 15 minutes
- Burner 4: 45 minutes
- Oven: 30 minutes

If each burner is rated at 1.2 kW and the oven at 1.8 kW, and electricity costs 12 cents per kWh, calculate the cost of electricity used in preparing the meal.

1.30 Reliant Energy (the electric company in Houston, Texas) charges customers as follows:

Monthly charge \$6

First 250 kWh @ \$0.02/kWh

All additional kWh @ \$0.07/kWh

If a customer uses 2,436 kWh in one month, how much will Reliant Energy charge?

1.31 In a household, a 120-W personal computer (PC) is run for 4 h/day, while a 60-W bulb runs for 8 h/day. If the utility company charges \$0.12/kWh, calculate how much the household pays per year on the PC and the bulb.

Comprehensive Problems

1.32 A telephone wire has a current of $20 \mu\text{A}$ flowing through it. How long does it take for a charge of 15 C to pass through the wire?

1.33 A lightning bolt carried a current of 2 kA and lasted for 3 ms. How many coulombs of charge were contained in the lightning bolt?

1.34 Figure 1.32 shows the power consumption of a certain household in 1 day. Calculate:

- (a) the total energy consumed in kWh,
- (b) the average power per hour over the total 24 hour period.

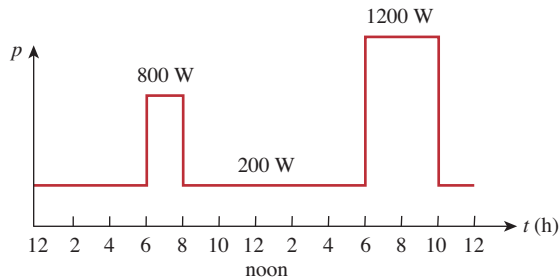

Figure 1.32

For Prob. 1.34.

1.35 The graph in Fig. 1.33 represents the power drawn by an industrial plant between 8:00 and 8:30 A.M. Calculate the total energy in MWh consumed by the plant.

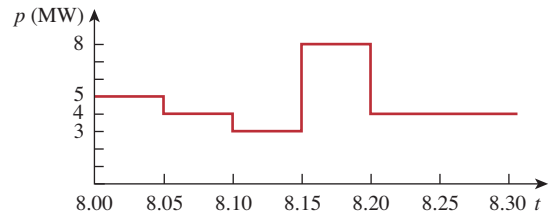

Figure 1.33

For Prob. 1.35.

1.36 A battery may be rated in ampere-hours (Ah). A lead-acid battery is rated at 160 Ah.

- (a) What is the maximum current it can supply for 40 h?
- (b) How many days will it last if it is discharged at 1 mA?

1.37 A 12-V battery requires a total charge of 40 ampere-hours during recharging. How many joules are supplied to the battery?

1.38 How much energy does a 10-hp motor deliver in 30 minutes? Assume that 1 horsepower = 746 W.

1.39 A 600-W TV receiver is turned on for 4 h with nobody watching it. If electricity costs 10 cents/kWh, how much money is wasted?

Chapter 1, Solution 1

(a) $q = 6.482 \times 10^{17} \times [-1.602 \times 10^{-19} \text{ C}] = \mathbf{-103.84 \text{ mC}}$

(b) $q = 1.24 \times 10^{18} \times [-1.602 \times 10^{-19} \text{ C}] = \mathbf{-198.65 \text{ mC}}$

(c) $q = 2.46 \times 10^{19} \times [-1.602 \times 10^{-19} \text{ C}] = \mathbf{-3.941 \text{ C}}$

(d) $q = 1.628 \times 10^{20} \times [-1.602 \times 10^{-19} \text{ C}] = \mathbf{-26.08 \text{ C}}$

Chapter 1, Solution 2

- (a) $i = dq/dt = 3 \text{ mA}$
- (b) $i = dq/dt = (16t + 4) \text{ A}$
- (c) $i = dq/dt = (-3e^{-t} + 10e^{-2t}) \text{ nA}$
- (d) $i = dq/dt = 1200\pi \cos 120\pi t \text{ pA}$
- (e) $i = dq/dt = -e^{-4t} (80 \cos 50t + 1000 \sin 50t) \mu\text{A}$

Chapter 1, Solution 3

$$(a) \quad q(t) = \int i(t)dt + q(0) = \underline{(3t + 1) \text{ C}}$$

$$(b) \quad q(t) = \int (2t + s) dt + q(v) = \underline{(t^2 + 5t) \text{ mC}}$$

$$(c) \quad q(t) = \int 20 \cos (10t + \pi / 6) + q(0) = \underline{(2 \sin(10t + \pi / 6) + 1) \mu\text{C}}$$

$$(d) \quad q(t) = \int 10e^{-30t} \sin 40t + q(0) = \frac{10e^{-30t}}{900 + 1600} (-30 \sin 40t - 40 \cos t)$$
$$= \underline{-e^{-30t} (0.16 \cos 40t + 0.12 \sin 40t) \text{ C}}$$

Chapter 1, Solution 4

$$q = it = 7.4 \times 20 = \underline{\underline{148 \text{ C}}}$$

Chapter 1, Solution 5

$$q = \int i dt = \int_0^{10} \frac{1}{2} t dt = \frac{t^2}{4} \Big|_0^{10} = \underline{\underline{25 \text{ C}}}$$

Chapter 1, Solution 6

(a) At $t = 1\text{ms}$, $i = \frac{dq}{dt} = \frac{30}{2} = \underline{\underline{15\text{ A}}}$

(b) At $t = 6\text{ms}$, $i = \frac{dq}{dt} = \underline{\underline{0\text{ A}}}$

(c) At $t = 10\text{ms}$, $i = \frac{dq}{dt} = \frac{-30}{4} = \underline{\underline{-7.5\text{ A}}}$

Chapter 1, Solution 7

$$i = \frac{dq}{dt} = \begin{cases} 25A, & 0 < t < 2 \\ -25A, & 2 < t < 6 \\ 25A, & 6 < t < 8 \end{cases}$$

which is sketched below:

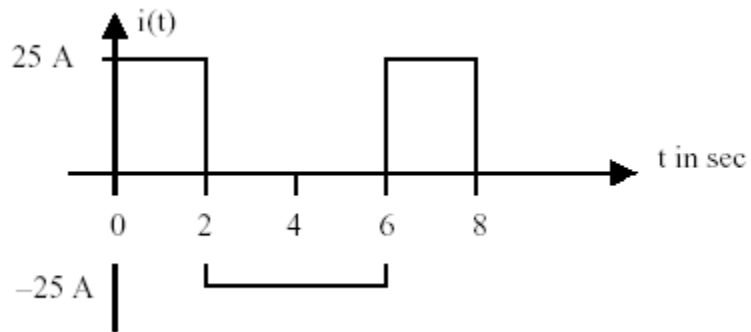

Chapter 1, Solution 8

$$q = \int i dt = \frac{10 \times 1}{2} + 10 \times 1 = \underline{15 \mu\text{C}}$$

Chapter 1, Solution 9

$$(a) \quad q = \int idt = \int_0^1 10 dt = \underline{10 C}$$

$$(b) \quad q = \int_0^3 idt = 10 \times 1 + \left(10 - \frac{5 \times 1}{2}\right) + 5 \times 1 \\ = 15 + 7.5 + 5 = \underline{22.5 C}$$

$$(c) \quad q = \int_0^5 idt = 10 + 10 + 10 = \underline{30 C}$$

Chapter 1, Solution 10

$$q = it = 10 \times 10^3 \times 15 \times 10^{-6} = \underline{\underline{150 \text{ mC}}}$$

Chapter 1, Solution 11

$$q = it = 90 \times 10^{-3} \times 12 \times 60 \times 60 = \mathbf{3.888 \text{ kC}}$$

$$E = pt = ivt = qv = 3888 \times 1.5 = \mathbf{5.832 \text{ kJ}}$$

Chapter 1, Solution 12

For $0 < t < 6\text{s}$, assuming $q(0) = 0$,

$$q(t) = \int_0^t i dt + q(0) = \int_0^t 3t dt + 0 = 1.5t^2$$

At $t=6$, $q(6) = 1.5(6)^2 = 54$

For $6 < t < 10\text{s}$,

$$q(t) = \int_6^t i dt + q(6) = \int_6^t 18 dt + 54 = 18t - 54$$

At $t=10$, $q(10) = 180 - 54 = 126$

For $10 < t < 15\text{s}$,

$$q(t) = \int_{10}^t i dt + q(10) = \int_{10}^t (-12) dt + 126 = -12t + 246$$

At $t=15$, $q(15) = -12 \times 15 + 246 = 66$

For $15 < t < 20\text{s}$,

$$q(t) = \int_{15}^t 0 dt + q(15) = 66$$

Thus,

$$q(t) = \begin{cases} 1.5t^2 \text{ C, } 0 < t < 6\text{s} \\ 18t - 54 \text{ C, } 6 < t < 10\text{s} \\ -12t + 246 \text{ C, } 10 < t < 15\text{s} \\ 66 \text{ C, } 15 < t < 20\text{s} \end{cases}$$

The plot of the charge is shown below.

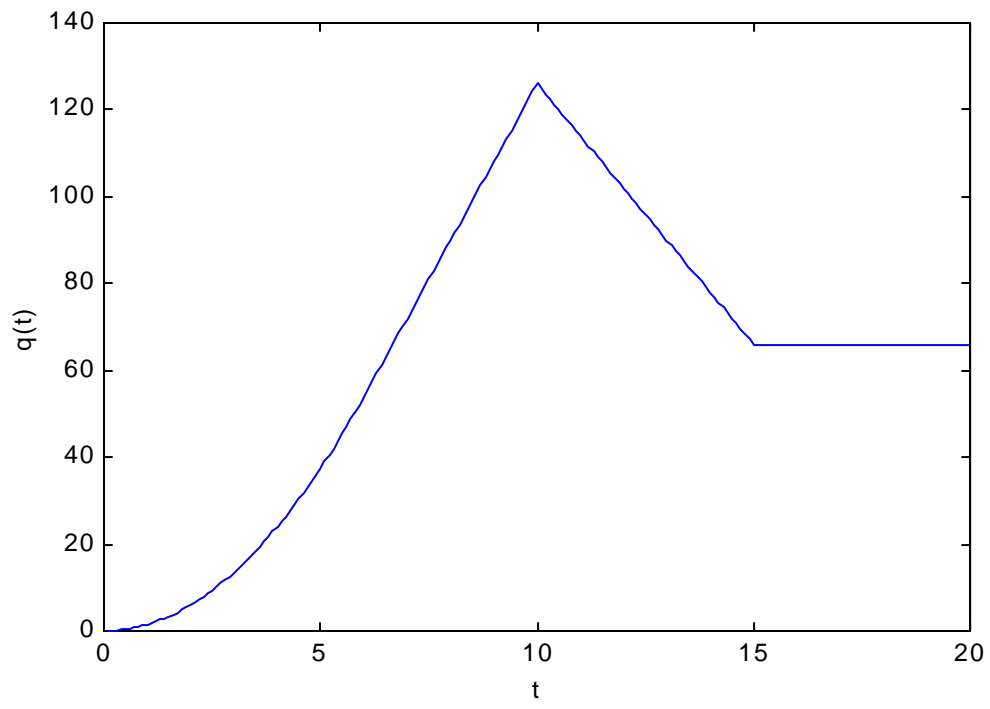

Chapter 1, Solution 13

(a) $i = [dq/dt] = 20\pi\cos(4\pi t)$ mA

$$p = vi = 60\pi\cos^2(4\pi t) \text{ mW}$$

At $t=0.3$ s,

$$p = vi = 60\pi\cos^2(4\pi \cdot 0.3) \text{ mW} = \mathbf{123.37 \text{ mW}}$$

(b) $W = \int p dt = 60\pi \int_0^{0.6} \cos^2(4\pi t) dt = 30\pi \int_0^{0.6} [1 + \cos(8\pi t)] dt$

$$W = 30\pi[0.6 + (1/(8\pi))[\sin(8\pi \cdot 0.6) - \sin(0)]] = \mathbf{58.76 \text{ mJ}}$$

Chapter 1, Solution 14

$$(a) \quad q = \int i dt = \int_0^1 0.02(1 - e^{-0.5t}) dt = 0.02(t + 2e^{-0.5t}) \Big|_0^1 = 0.02(1 + 2e^{-0.5} - 2) = \mathbf{4.261 \text{ mC}}$$

$$(b) \quad p(t) = v(t)i(t) \\ p(1) = 10\cos(2) \times 0.02(1 - e^{-0.5}) = (-4.161)(0.007869) \\ = \mathbf{-32.74 \text{ mW}}$$

Chapter 1, Solution 15

$$\begin{aligned}
 \text{(a)} \quad q &= \int i dt = \int_0^2 0.006e^{-2t} dt = \left. \frac{-0.006}{2} e^{2t} \right|_0^2 \\
 &= -0.003(e^{-4} - 1) = \\
 &\quad \mathbf{2.945 \text{ mC}}
 \end{aligned}$$

$$\begin{aligned}
 \text{(b)} \quad v &= \frac{10di}{dt} = -0.012e^{-2t}(10) = -0.12e^{-2t} \text{ V this leads to } p(t) = v(t)i(t) = \\
 &(-0.12e^{-2t})(0.006e^{-2t}) = \mathbf{-720e^{-4t} \mu\text{W}}
 \end{aligned}$$

$$\text{(c)} \quad w = \int p dt = -0.72 \int_0^3 e^{-4t} dt = \left. \frac{-720}{-4} e^{-4t} 10^{-6} \right|_0^3 = \mathbf{-180 \mu\text{J}}$$

Chapter 1, Solution 16

(a)

$$i(t) = \begin{cases} 30t \text{ mA}, & 0 < t < 2 \\ 120 - 30t \text{ mA}, & 2 < t < 4 \end{cases}$$

$$v(t) = \begin{cases} 5 \text{ V}, & 0 < t < 2 \\ -5 \text{ V}, & 2 < t < 4 \end{cases}$$

$$p(t) = \begin{cases} 150t \text{ mW}, & 0 < t < 2 \\ -600 + 150t \text{ mW}, & 2 < t < 4 \end{cases}$$

which is sketched below.

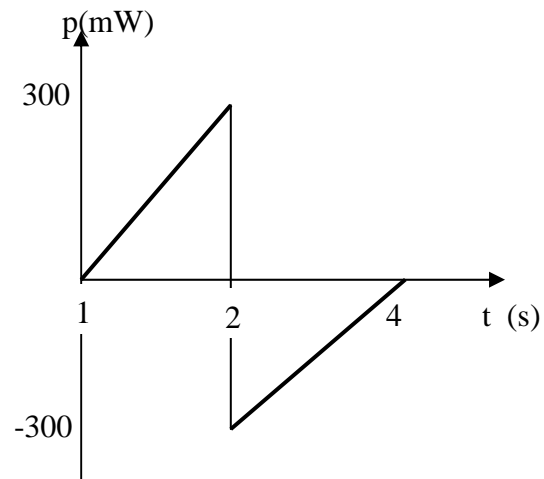

(b) From the graph of p ,

$$W = \int_0^4 p dt = \underline{0 \text{ J}}$$

Chapter 1, Solution 17

$$\sum p = 0 \rightarrow -205 + 60 + 45 + 30 + p_3 = 0$$

$$p_3 = 205 - 135 = 70 \text{ W}$$

Thus element 3 receives **70 W**.

Chapter 1, Solution 18

$$p_1 = 30(-10) = \mathbf{-300\ W}$$

$$p_2 = 10(10) = \mathbf{100\ W}$$

$$p_3 = 20(14) = \mathbf{280\ W}$$

$$p_4 = 8(-4) = \mathbf{-32\ W}$$

$$p_5 = 12(-4) = \mathbf{-48\ W}$$

Chapter 1, Solution 19

$$I = 8 - 2 = \mathbf{6 \text{ A}}$$

Calculating the power absorbed by each element means we need to find v_i for each element.

$$\begin{aligned} p_{8 \text{ amp source}} &= -8 \times 9 = \mathbf{-72 \text{ W}} \\ p_{\text{element with 9 volts across it}} &= 2 \times 9 = \mathbf{18 \text{ W}} \\ p_{\text{element with 3 volts across it}} &= 3 \times 6 = \mathbf{18 \text{ W}} \\ p_{6 \text{ volt source}} &= 6 \times 6 = \mathbf{36 \text{ W}} \end{aligned}$$

One check we can use is that the sum of the power absorbed must equal zero which is what it does.

Chapter 1, Solution 20

$$P_{30 \text{ volt source}} = 30 \times (-6) = \mathbf{-180 \text{ W}}$$

$$P_{12 \text{ volt element}} = 12 \times 6 = \mathbf{72 \text{ W}}$$

$$P_{28 \text{ volt element with 2 amps flowing through it}} = 28 \times 2 = \mathbf{56 \text{ W}}$$

$$P_{28 \text{ volt element with 1 amp flowing through it}} = 28 \times 1 = \mathbf{28 \text{ W}}$$

$$P_{\text{the } 5I_o \text{ dependent source}} = 5 \times 2 \times (-3) = \mathbf{-30 \text{ W}}$$

Since the total power absorbed by all the elements in the circuit must equal zero, or $0 = -180 + 72 + 56 + 28 - 30 + P_{\text{into the element with } V_o}$ or

$$P_{\text{into the element with } V_o} = 180 - 72 - 56 - 28 + 30 = \mathbf{54 \text{ W}}$$

Since $P_{\text{into the element with } V_o} = V_o \times 3 = 54 \text{ W}$ or $V_o = \mathbf{18 \text{ V}}$.

Chapter 1, Solution 21

$$p = vi \quad \longrightarrow \quad i = \frac{p}{v} = \frac{60}{120} = 0.5 \text{ A}$$

$$q = it = 0.5 \times 24 \times 60 \times 60 = \mathbf{43.2 \text{ kC}}$$

$$N_e = q \times 6.24 \times 10^{18} = \underline{2.696 \times 10^{23} \text{ electrons}}$$

Chapter 1, Solution 22

$$q = it = 40 \times 10^3 \times 1.7 \times 10^{-3} = \mathbf{68 \text{ C}}$$

Chapter 1, Solution 23

$$W = pt = 1.8 \times (15/60) \times 30 \text{ kWh} = 13.5 \text{ kWh}$$

$$C = 10 \text{ cents} \times 13.5 = \mathbf{\$1.35}$$

Chapter 1, Solution 24

$$W = pt = 60 \times 24 \text{ Wh} = 0.96 \text{ kWh} = 1.44 \text{ kWh}$$

$$C = 8.2 \text{ cents} \times 0.96 = \mathbf{11.808 \text{ cents}}$$

Chapter 1, Solution 25

$$\text{Cost} = 1.5 \text{ kW} \times \frac{3.5}{60} \text{ hr} \times 30 \times 8.2 \text{ cents/kWh} = \mathbf{21.52 \text{ cents}}$$

Chapter 1, Solution 26

(a) $i = \frac{0.8\text{A} \cdot \text{h}}{10\text{h}} = \mathbf{80\text{ mA}}$

(b) $p = vi = 6 \times 0.08 = \mathbf{0.48\text{ W}}$

(c) $w = pt = 0.48 \times 10\text{ Wh} = \mathbf{0.0048\text{ kWh}}$

Chapter 1, Solution 27

(a) Let $T = 4h = 4 \times 3600$

$$q = \int i dt = \int_0^T 3 dt = 3T = 3 \times 4 \times 3600 = \underline{43.2 \text{ kC}}$$

(b) $W = \int p dt = \int_0^T v i dt = \int_0^T (3) \left(10 + \frac{0.5t}{3600} \right) dt$

$$= 3 \left(10t + \frac{0.25t^2}{3600} \right) \Big|_0^{4 \times 3600} = 3[40 \times 3600 + 0.25 \times 16 \times 3600]$$
$$= \underline{475.2 \text{ kJ}}$$

(c) $W = 475.2 \text{ kWs}, \quad (J = \text{Ws})$

$$\text{Cost} = \frac{475.2}{3600} \text{ kWh} \times 9 \text{ cent} = \underline{1.188 \text{ cents}}$$

Chapter 1, Solution 28

$$(a) \quad i = \frac{P}{V} = \frac{60}{120}$$

$$= \mathbf{500 \text{ mA}}$$

$$(b) \quad W = pt = 60 \times 365 \times 24 \text{ Wh} = 525.6 \text{ kWh}$$

$$\text{Cost} = \$0.095 \times 525.6$$

$$= \mathbf{\$49.93}$$

Chapter 1, Solution 29

$$w = pt = 1.2\text{kW} \frac{(20 + 40 + 15 + 45)}{60} \text{hr} + 1.8\text{kW} \left(\frac{30}{60} \right) \text{hr}$$

$$= 2.4 + 0.9 = 3.3\text{kWh}$$

$$\text{Cost} = 12 \text{ cents} \times 3.3 = \underline{39.6 \text{ cents}}$$

Chapter 1, Solution 30

Monthly charge = \$6

First 250 kWh @ \$0.02/kWh = \$5

Remaining 2,436–250 kWh = 2,186 kWh @ \$0.07/kWh= \$153.02

Total = \$164.02

Chapter 1, Solution 31

$$\text{Total energy consumed} = 365(120 \times 4 + 60 \times 8) \text{ W}$$

$$\text{Cost} = \$0.12 \times 365 \times 960 / 1000 = \mathbf{\$42.05}$$

Chapter 1, Solution 32

$$i = 20 \mu\text{A}$$

$$q = 15 \text{ C}$$

$$t = q/i = 15/(20 \times 10^{-6}) = \mathbf{750 \times 10^3 \text{ hrs}}$$

Chapter 1, Solution 33

$$i = \frac{dq}{dt} \rightarrow q = \int i dt = 2000 \times 3 \times 10^{-3} = \underline{6 \text{ C}}$$

Chapter 1, Solution 34

(a) Energy = $\sum pt = 200 \times 6 + 800 \times 2 + 200 \times 10 + 1200 \times 4 + 200 \times 2$
 = **10 kWh**

(b) Average power = $10,000/24 = \mathbf{416.7 \text{ W}}$

Chapter 1, Solution 35

$$\text{energy} = (5 \times 5 + 4 \times 5 + 3 \times 5 + 8 \times 5 + 4 \times 10) / 60 = \mathbf{2.333 \text{ MWhr}}$$

Chapter 1, Solution 36

$$(a) \quad i = \frac{160\text{A} \cdot \text{h}}{40} = \underline{4 \text{ A}}$$

$$(b) \quad t = \frac{160\text{Ah}}{0.001\text{A}} = \frac{160,000\text{h}}{24\text{h / day}} = \underline{6,667 \text{ days}}$$

Chapter 1, Solution 37

$$W = pt = vit = 12 \times 40 \times 60 \times 60 = \mathbf{1.728 \text{ MJ}}$$

Chapter 1, Solution 38

$$P = 10 \text{ hp} = 7460 \text{ W}$$

$$W = pt = 7460 \times 30 \times 60 \text{ J} = \mathbf{13.43 \times 10^6 \text{ J}}$$

Chapter 1, Solution 39

$$W = pt = 600 \times 4 = 2.4 \text{ kWh}$$

$$C = 10 \text{ cents} \times 2.4 = \mathbf{24 \text{ cents}}$$