

# Chapter 8

## Impulse and Momentum

**THE LINEAR MOMENTUM** ( $\vec{p}$ ) of a body is the product of its mass ( $m$ ) and velocity ( $\vec{v}$ ):

Linear momentum = (mass of body) (velocity of body)

$$\vec{p} = m\vec{v}$$

Momentum is a vector quantity whose direction is that of the velocity. The units of momentum are kg·m/s in the SI.

**AN IMPULSE** is the product of a force ( $\vec{F}$ ) and the time interval ( $\Delta t$ ) over which the force acts:

Impulse = (force) (length of time the force acts)

Impulse is a vector quantity whose direction is that of the force. Its units are N·s in the SI.

**AN IMPULSE CAUSES A CHANGE IN MOMENTUM:** The change of momentum produced by an impulse is equal to the impulse in both magnitude and direction. Thus, if a constant force  $\vec{F}$  acting for a time  $\Delta t$  on a body of mass  $m$  changes its velocity from an initial value  $\vec{v}_i$  to a final value  $\vec{v}_f$ , then

Impulse = change in momentum

$$\vec{F} \Delta t = m(\vec{v}_f - \vec{v}_i)$$

Newton's Second Law, as he gave it, is  $\vec{F} = \Delta\vec{p}/\Delta t$  from which it follows that  $\vec{F} \Delta t = \Delta\vec{p}$ . Moreover,  $\vec{F} \Delta t = \Delta(m\vec{v})$  and if  $m$  is constant  $\vec{F} \Delta t = m(\vec{v}_f - \vec{v}_i)$ .

**CONSERVATION OF LINEAR MOMENTUM:** If the net external force acting on a system of objects is zero, the vector sum of the momenta of the objects will remain constant.

**IN COLLISIONS AND EXPLOSIONS**, the vector sum of the momenta just before the event equals the vector sum of the momenta just after the event. The vector sum of the momenta of the objects involved does not change during the collision or explosion.

Thus, when two bodies of masses  $m_1$  and  $m_2$  collide,

Total momentum before impact = total momentum after impact

$$m_1\vec{u}_1 + m_2\vec{u}_2 = m_1\vec{v}_1 + m_2\vec{v}_2$$

where  $\vec{u}_1$  and  $\vec{u}_2$  are the velocities before impact, and  $\vec{v}_1$  and  $\vec{v}_2$  are the velocities after. In one dimension, in component form,

$$m_1u_{1x} + m_2u_{2x} = m_1v_{1x} + m_2v_{2x}$$

and similarly for the  $y$ - and  $z$ -components. Remember that vector quantities are always boldfaced and velocity is a vector. On the other hand,  $u_{1x}$ ,  $u_{2x}$ ,  $v_{1x}$ , and  $v_{2x}$  are the scalar values of the velocities (they can be positive or negative). A positive direction is initially selected and vectors pointing opposite to this have negative numerical scalar values.

A **PERFECTLY ELASTIC COLLISION** is one in which the sum of the translational KEs of the objects is not changed during the collision. In the case of two bodies,

$$\frac{1}{2}m_1u_1^2 + \frac{1}{2}m_2u_2^2 = \frac{1}{2}m_1v_1^2 + \frac{1}{2}m_2v_2^2$$

**COEFFICIENT OF RESTITUTION:** For any collision between two bodies in which the bodies move only along a single straight line (e.g., the  $x$ -axis), a *coefficient of restitution*  $e$  is defined. It is a pure number given by

$$e = \frac{v_{2x} - v_{1x}}{u_{1x} - u_{2x}}$$

where  $u_{1x}$  and  $u_{2x}$  are values before impact, and  $v_{1x}$  and  $v_{2x}$  are values after impact. Notice that  $|u_{1x} - u_{2x}|$  is the relative speed of approach and  $|v_{2x} - v_{1x}|$  is the relative speed of recession.

For a perfectly elastic collision,  $e = 1$ . For inelastic collisions,  $e < 1$ . If the bodies stick together after collision,  $e = 0$ .

**THE CENTER OF MASS** of an object (of mass  $m$ ) is the single point that moves in the same way as a point mass (of mass  $m$ ) would move when subjected to the same external forces that act on the object. That is, if the resultant force acting on an object (or system of objects) of mass  $m$  is  $\vec{F}$ , the acceleration of the center of mass of the object (or system) is given by  $\vec{a}_{\text{cm}} = \vec{F}/m$ .

If the object is considered to be composed of tiny masses  $m_1, m_2, m_3$ , and so on, at coordinates  $(x_1, y_1, z_1), (x_2, y_2, z_2)$ , and so on, then the coordinates of the center of mass are given by

$$x_{\text{cm}} = \frac{\sum x_i m_i}{\sum m_i} \quad y_{\text{cm}} = \frac{\sum y_i m_i}{\sum m_i} \quad z_{\text{cm}} = \frac{\sum z_i m_i}{\sum m_i}$$

where the sums extend over all masses composing the object. In a uniform gravitational field, the center of mass and the center of gravity coincide.

## Solved Problems

8.1

An 8.0-g bullet is fired horizontally into a 9.00-kg cube of wood, which is at rest, and sticks in it. The cube is free to move and has a speed of 40 cm/s after impact. Find the initial velocity of the bullet.

Consider the system (cube + bullet). The velocity, and hence the momentum, of the cube before impact is zero. Take the bullet's initial motion to be positive in the positive  $x$ -direction. The momentum conservation law tells us that

$$\begin{aligned} \text{Momentum of system before impact} &= \text{momentum of system after impact} \\ (\text{momentum of bullet}) + (\text{momentum of cube}) &= (\text{momentum of bullet + cube}) \end{aligned}$$

$$\begin{aligned} m_B v_{Bx} + m_C v_{Cx} &= (m_B + m_C) v_x \\ (0.0080 \text{ kg}) v_{Bx} + 0 &= (9.008 \text{ kg})(0.40 \text{ m/s}) \end{aligned}$$

Solving gives  $v_{Bx} = 0.45 \text{ km/s}$  and so  $\vec{v}_B = 0.45 \text{ km/s}$  — POSITIVE  $x$ -DIRECTION.

- 8.2 A 16-g mass is moving in the  $+x$ -direction at 30 cm/s while a 4.0-g mass is moving in the  $-x$ -direction at 50 cm/s. They collide head on and stick together. Find their velocity after the collision.

Let the 16-g mass be  $m_1$  and the 4.0-g mass be  $m_2$ .

Take the  $+x$ -direction to be positive. That means that the velocity of the 4.0-g mass has a scalar value of  $v_{2x} = -50$  cm/s. We apply the law of conservation of momentum to the system consisting of the two masses:

Momentum before impact = momentum after impact

$$m_1 v_{1x} + m_2 v_{2x} = (m_1 + m_2) v_x$$

$$(0.016 \text{ kg})(0.30 \text{ m/s}) + (0.0040 \text{ kg})(-0.50 \text{ m/s}) = (0.020 \text{ kg})v_x$$

$$v_x = +0.14 \text{ m/s}$$

(Notice that the 4.0-g mass has negative momentum.) Hence,  $\vec{v} = 0.14 \text{ m/s}$  — POSITIVE  $x$ -DIRECTION.

- 8.3 A 2.0-kg brick is moving at a speed of 6.0 m/s. How large a force  $F$  is needed to stop the brick in a time of  $7.0 \times 10^{-4}$  s?

Let us solve this by use of the impulse equation:

Impulse on brick = change in momentum of brick

$$F \Delta t = mv_f - mv_i$$

$$F(7.0 \times 10^{-4} \text{ s}) = 0 - (2.0 \text{ kg})(6.0 \text{ m/s})$$

from which  $F = -1.7 \times 10^4$  N. The minus sign indicates that the force opposes the motion.

- 8.4 A 15-g bullet moving at 300 m/s passes through a 2.0 cm thick sheet of foam plastic and emerges with a speed of 90 m/s. What average force impeded its motion through the plastic?

Use the impulse equation to find the force  $F$  on the bullet as it takes a time  $\Delta t$  to pass through the plastic. Taking the initial direction of motion to be positive,

$$F \Delta t = mv_f - mv_i$$

We can find  $\Delta t$  by assuming uniform deceleration and using  $x = v_{av} t$ , where  $x = 0.020$  m and  $v_{av} = \frac{1}{2}(v_i + v_f) = 195$  m/s. This gives  $\Delta t = 1.026 \times 10^{-4}$  s. Then

$$(F)(1.026 \times 10^{-4} \text{ s}) = (0.015 \text{ kg})(90 \text{ m/s}) - (0.015 \text{ kg})(300 \text{ m/s})$$

which gives  $F = -3.1 \times 10^4$  N as the average retarding force. How could this problem have been solved using  $F = ma$  instead of the impulse equation? By using energy methods?

- 8.5 The nucleus of an atom has a mass of  $3.80 \times 10^{-25}$  kg and is at rest. The nucleus is radioactive and suddenly ejects a particle of mass  $6.6 \times 10^{-27}$  kg and speed  $1.5 \times 10^7$  m/s. Find the recoil speed of the nucleus that is left behind.

Take the direction of the ejected particle as positive. We are given,  $m_{ni} = 3.80 \times 10^{-25}$  kg,  $m_p = 6.6 \times 10^{-27}$  kg,  $m_{nf} = m_{ni} - m_p = 3.73 \times 10^{-25}$  kg, and  $v_{pf} = 1.5 \times 10^7$  m/s; find the final speed of the nucleus,  $v_{nf}$ . The momentum of the system is conserved during the explosion.

Momentum before = momentum after

$$0 = m_{nf} v_{nf} + m_p v_{pf}$$

$$0 = (3.73 \times 10^{-25} \text{ kg})(v_{nf}) + (6.6 \times 10^{-27} \text{ kg})(1.5 \times 10^7 \text{ m/s})$$

Solving gives

$$-v_{nf} = \frac{(6.6 \times 10^{-27} \text{ kg})(1.5 \times 10^7 \text{ m/s})}{3.73 \times 10^{-25} \text{ kg}} = \frac{10.0 \times 10^{-20}}{3.73 \times 10^{-25}} = 2.7 \times 10^5 \text{ m/s}$$

The fact that this is negative tells us that the velocity vector of the nucleus points in the negative direction, opposite to the velocity of the particle.

- 8.6 A 0.25-kg ball moving in the  $+x$ -direction at 13 m/s is hit by a bat. Its final velocity is 19 m/s in the  $-x$ -direction. The bat acts on the ball for 0.010 s. Find the average force  $F$  exerted on the ball by the bat.

We have  $v_i = 13 \text{ m/s}$  and  $v_f = -19 \text{ m/s}$ . Taking the initial direction of motion as positive, the impulse equation then gives

$$F \Delta t = mv_f - mv_i$$

$$F(0.010 \text{ s}) = (0.25 \text{ kg})(-19 \text{ m/s}) - (0.25 \text{ kg})(13 \text{ m/s})$$

from which  $F = -0.80 \text{ kN}$ .

- 8.7 Two girls (masses  $m_1$  and  $m_2$ ) are on roller skates and stand at rest, close to each other and face to face. Girl 1 pushes squarely against girl 2 and sends her moving backward. Assuming the girls move freely on their skates, with what speed does girl 1 move?

We take the two girls to comprise the system under consideration. The problem states that girl 2 moves "backward," so let that be the negative direction; therefore the "forward" direction is positive. There is no resultant external force on the system (the push of one girl on the other is an internal force), and so momentum is conserved:

$$\text{Momentum before} = \text{momentum after}$$

$$0 = m_1 v_1 + m_2 v_2$$

from which

$$v_1 = -\frac{m_2}{m_1} v_2$$

Girl 1 recoils with this speed. Notice that if  $m_2/m_1$  is very large,  $v_1$  is much larger than  $v_2$ . The velocity of girl 1,  $\vec{v}_1$ , points in the positive forward direction. The velocity of girl 2,  $\vec{v}_2$ , points in the negative backward direction. If we put numbers into the equation,  $v_2$  would have to be negative and  $v_1$  would come out positive.

8.8

As shown in Fig. 8-1, a 15-g bullet is fired horizontally into a 3.000-kg block of wood suspended by a long cord. The bullet sticks in the block. Compute the speed of the bullet if the impact causes the block to swing 10 cm above its initial level.

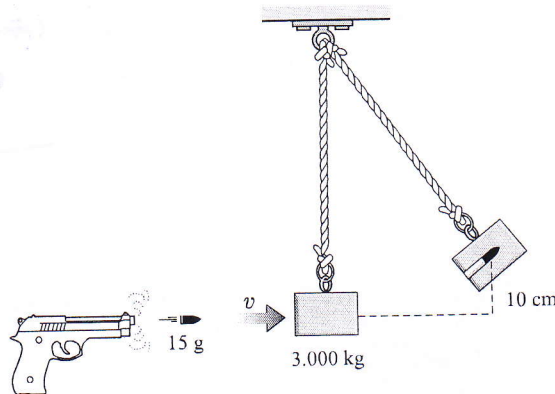

Fig. 8-1

Consider first the collision of block and bullet. During the collision, momentum is conserved, so

Momentum just before = momentum just after

$$(0.015 \text{ kg})v + 0 = (3.015 \text{ kg})V$$

where  $v$  is the initial speed of the bullet, and  $V$  is the speed of block and bullet just after collision.

We have two unknowns in this equation. To find another equation, we can use the fact that the block swings 10 cm high. If we let  $PE_G = 0$  at the initial level of the block, energy conservation gives

KE just after collision = final  $PE_G$

$$\frac{1}{2}(3.015 \text{ kg})V^2 = (3.015 \text{ kg})(9.81 \text{ m/s}^2)(0.10 \text{ m}) \quad mgh$$

From this we find  $V = 1.40 \text{ m/s}$ . Substituting this in the previous equation gives  $v = 0.28 \text{ km/s}$  for the speed of the bullet.

Notice that we cannot write the conservation of energy equation  $\frac{1}{2}mv^2 = (m+M)gh$ , where  $m = 0.015 \text{ kg}$  and  $M = 3.000 \text{ kg}$  because energy is lost (through friction) in the collision process.

- 8.9 Three masses are placed on the  $x$ -axis: 200 g at  $x = 0$ , 500 g at  $x = 30 \text{ cm}$ , and 400 g at  $x = 70 \text{ cm}$ . Find their center of mass.

$$x_{\text{cm}} = \frac{\sum x_i m_i}{\sum m_i} = \frac{(0)(0.20 \text{ kg}) + (0.30 \text{ m})(0.50 \text{ kg}) + (0.70 \text{ m})(0.40 \text{ kg})}{(0.20 + 0.50 + 0.40) \text{ kg}} = 0.39 \text{ m}$$

The  $y$ - and  $z$ -coordinates of the mass center are zero.

- 8.10 A system consists of the following masses in the  $xy$ -plane: 4.0 kg at coordinates  $(x = 0, y = 5.0 \text{ m})$ , 7.0 kg at  $(3.0 \text{ m}, 8.0 \text{ m})$ , and 5.0 kg at  $(-3.0 \text{ m}, -6.0 \text{ m})$ . Find the position of its center of mass.

$$x_{\text{cm}} = \frac{\sum x_i m_i}{\sum m_i} = \frac{(0)(4.0 \text{ kg}) + (3.0 \text{ m})(7.0 \text{ kg}) + (-3.0 \text{ m})(5.0 \text{ kg})}{(4.0 + 7.0 + 5.0) \text{ kg}} = 0.38 \text{ m}$$

$$y_{\text{cm}} = \frac{\sum y_i m_i}{\sum m_i} = \frac{(5.0 \text{ m})(4.0 \text{ kg}) + (8.0 \text{ m})(7.0 \text{ kg}) + (-6.0 \text{ m})(5.0 \text{ kg})}{16 \text{ kg}} = 2.9 \text{ m}$$

and  $z_{\text{cm}} = 0$ .

- 8.11 Two identical railroad cars sit on a horizontal track, with a distance  $D$  between their centers. By means of a cable between them, a winch on one is used to pull the two together. (a) Describe their relative motion. (b) Repeat if the mass of one car is three times that of the other.

The forces due to the cable on the two cars are internal forces for the two-car system. The net external force on the system is zero, and so its center of mass does not move, even though each car moves toward the other. Taking the origin of coordinates at the mass center, we have

$$x_{\text{cm}} = 0 = \frac{\sum m_i x_i}{\sum m_i} = \frac{m_1 x_1 + m_2 x_2}{m_1 + m_2}$$

where  $x_1$  and  $x_2$  are the positions of the centers of the two cars.

- (a) If  $m_1 = m_2$ , this equation becomes

$$0 = \frac{x_1 + x_2}{2} \quad \text{or} \quad x_1 = -x_2$$

The two cars approach the center of mass, which is originally midway between the two cars (that is,  $D/2$  from each), in such a way that their centers are always equidistant from it.

- (b) If  $m_1 = 3m_2$ , then we have

$$0 = \frac{3m_2 x_1 + m_2 x_2}{3m_2 + m_2} = \frac{3x_1 + x_2}{4}$$

from which  $x_1 = -x_2/3$ . The two cars approach each other in such a way that the mass center remains motionless and the heavier car is always one-third as far away from it as the lighter car.

Originally, because  $|x_1| + |x_2| = D$ , we had  $x_2/3 + x_2 = D$ . So  $m_2$  was originally a distance  $x_2 = 3D/4$  from the mass center, and  $m_1$  was a distance  $D/4$  from it.

- 8.12** A pendulum consisting of a ball of mass  $m$  is released from the position shown in Fig. 8-2 and strikes a block of mass  $M$ . The block slides a distance  $D$  before stopping under the action of a steady friction force  $0.20Mg$ . Find  $D$  if the ball rebounds to an angle of  $20^\circ$ .

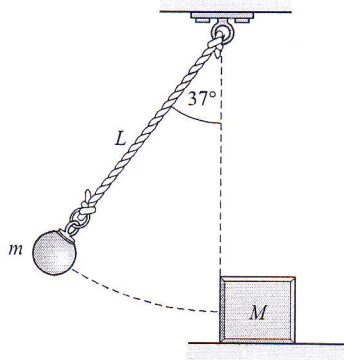

Fig. 8-2

The pendulum ball falls through a height  $(L - L \cos 37^\circ) = 0.201L$  and rebounds to a height  $(L - L \cos 20^\circ) = 0.0603L$ . Because  $(mgh)_{\text{top}} = (\frac{1}{2}mv^2)_{\text{bottom}}$  for the ball, its speed at the bottom is  $v = \sqrt{2gh}$ .

Although KE is not conserved in the collision, momentum is. Therefore, for the collision,

Momentum just before = momentum just after

$$m\sqrt{2g(0.201L)} + 0 = -m\sqrt{2g(0.0603L)} + MV$$

where  $V$  is the velocity of the block just after the collision. (Notice the minus sign on the momentum of the rebounding ball.) Solving this equation, we find

$$V = \frac{m}{M} 0.981 \sqrt{gL}$$

The block uses up its translational KE doing work against friction as it slides a distance  $D$ . Therefore,

$$\frac{1}{2}MV^2 = F_f D \quad \text{or} \quad \frac{1}{2}M(0.963gL) \left(\frac{m}{M}\right)^2 = (0.2Mg)(D)$$

from which  $D = 2.4(m/M)^2 L$ .

- 8.13** Two balls of equal mass approach the coordinate origin, one moving downward along the  $+y$ -axis at 2.00 m/s and the other moving to the right along the  $-x$ -axis at 3.00 m/s. After they collide, one ball moves out to the right along the  $+x$ -axis at 1.20 m/s. Find the scalar  $x$  and  $y$  velocity components of the other ball.

Take *up* and to the *right* as positive. Momentum is conserved in the collision, so we can write

or  
and  
or

$$\begin{aligned} (\text{momentum before})_x &= (\text{momentum after})_x \\ m(3.00 \text{ m/s}) + 0 &= m(1.20 \text{ m/s}) + mv_x \\ (\text{momentum before})_y &= (\text{momentum after})_y \\ 0 + m(-2.00 \text{ m/s}) &= 0 + mv_y \end{aligned}$$

(Why the minus sign?) Solving, we find that  $v_x = 1.80 \text{ m/s}$  and  $v_y = -2.00 \text{ m/s}$ .

**8.14** A 7500-kg truck traveling at 5.0 m/s east collides with a 1500-kg car moving at 20 m/s in a direction 30° south of west. After collision, the two vehicles remain tangled together. With what speed and in what direction does the wreckage begin to move?

The original momenta are shown in Fig. 8-3(a), while the final momentum  $M\vec{v}$  is shown in Fig. 8-3(b). Momentum must be conserved in both the north and east directions. Therefore,

$$\begin{aligned} (\text{momentum before})_E &= (\text{momentum after})_E \\ (7500 \text{ kg})(5.0 \text{ m/s}) - (1500 \text{ kg})[(20 \text{ m/s}) \cos 30^\circ] &= Mv_E = 1.28 \end{aligned}$$

where  $M = 7500 \text{ kg} + 1500 \text{ kg} = 9000 \text{ kg}$ , and  $v_E$  is the scalar eastward component of the velocity of the wreckage.

$$\begin{aligned} (\text{momentum before})_N &= (\text{momentum after})_N \\ (7500 \text{ kg})(0) - (1500 \text{ kg})[(20 \text{ m/s}) \sin 30^\circ] &= Mv_N \end{aligned}$$

The first equation gives  $v_E = 1.28 \text{ m/s}$ , and the second gives  $v_N = -1.67 \text{ m/s}$ . The resultant is

$$v = \sqrt{(1.67 \text{ m/s})^2 + (1.28 \text{ m/s})^2} = 2.1 \text{ m/s}$$

The angle  $\theta$  in Fig. 8-3(b) is

$$\theta = \arctan\left(\frac{1.67}{1.28}\right) = 53^\circ$$

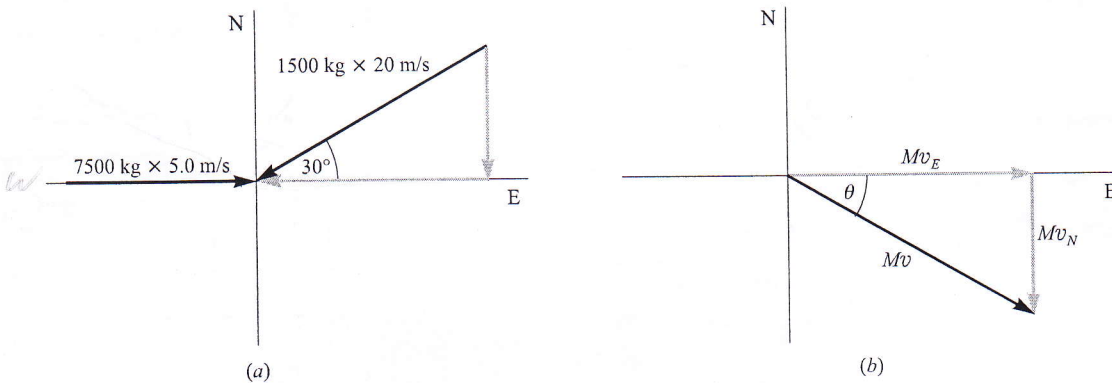

Fig. 8-3

**8.15** Two identical balls collide head-on. The initial velocity of one is 0.75 m/s—EAST, while that of the other is 0.43 m/s—WEST. If the collision is perfectly elastic, what is the final velocity of each ball?

Since the collision is head-on, all motion takes place along a straight line. Take east as positive and call the mass of each ball  $m$ . Momentum is conserved in a collision, so we can write

Momentum before = momentum after

$$m(0.75 \text{ m/s}) + m(-0.43 \text{ m/s}) = mv_1 + mv_2$$

where  $v_1$  and  $v_2$  are the final values. This equation simplifies to

$$0.32 \text{ m/s} = v_1 + v_2 \quad (1)$$

Because the collision is assumed to be perfectly elastic, KE is also conserved. Thus,

KE before = KE after

$$\frac{1}{2}m(0.75 \text{ m/s})^2 + \frac{1}{2}m(0.43 \text{ m/s})^2 = \frac{1}{2}mv_1^2 + \frac{1}{2}mv_2^2$$

This equation can be simplified to

$$0.747 = v_1^2 + v_2^2 \quad (2)$$

We can solve for  $v_2$  in (1) to get  $v_2 = 0.32 - v_1$  and substitute this in (2). This yields

$$0.747 = (0.32 - v_1)^2 + v_1^2$$

from which

$$2v_1^2 - 0.64v_1 - 0.645 = 0$$

Using the quadratic formula, we find that

$$v_1 = \frac{-b \pm \sqrt{b^2 - 4ac}}{4a} = 0.16 \pm 0.59 \text{ m/s}$$

from which  $v_1 = 0.75 \text{ m/s}$  or  $-0.43 \text{ m/s}$ . Substitution back into Eq. (1) gives  $v_2 = -0.43 \text{ m/s}$  or  $0.75 \text{ m/s}$ .

Two choices for answers are available:

$$(v_1 = 0.75 \text{ m/s}, v_2 = -0.43 \text{ m/s}) \quad \text{and} \quad (v_1 = -0.43 \text{ m/s}, v_2 = 0.75 \text{ m/s})$$

We must discard the first choice because it implies that the balls continue on unchanged; that is to say, no collision occurred. The correct answer is therefore  $v_1 = -0.43 \text{ m/s}$  and  $v_2 = 0.75 \text{ m/s}$ , which tells us that in a perfectly elastic, head-on collision between equal masses, the two bodies simply exchange velocities. Hence  $\vec{v}_1 = 0.43 \text{ m/s}$  — WEST and  $\vec{v}_2 = 0.75 \text{ m/s}$  — EAST.

#### Alternative Method

If we recall that  $e = 1$  for a perfectly elastic head-on collision, then

$$e = \frac{v_2 - v_1}{u_1 - u_2} \quad \text{becomes} \quad 1 = \frac{v_2 - v_1}{(0.75 \text{ m/s}) - (-0.43 \text{ m/s})}$$

which gives

$$v_2 - v_1 = 1.18 \text{ m/s} \quad (3)$$

Equations (1) and (3) determine  $v_1$  and  $v_2$  uniquely.

- 8.16** A 1.0-kg ball moving at 12 m/s collides head-on with a 2.0-kg ball moving in the opposite direction at 24 m/s. Determine the motion of each after impact if (a)  $e = 2/3$ , (b) the balls stick together, and (c) the collision is perfectly elastic.

In all three cases momentum is conserved, and so we can write

Momentum before = momentum after

$$(1.0 \text{ kg})(12 \text{ m/s}) + (2.0 \text{ kg})(-24 \text{ m/s}) = (1.0 \text{ kg})v_1 + (2.0 \text{ kg})v_2$$

which becomes

$$-36 \text{ m/s} = v_1 + 2v_2$$

(a) When  $e = 2/3$ ,

$$e = \frac{v_2 - v_1}{u_1 - u_2} \quad \text{becomes} \quad \frac{2}{3} = \frac{v_2 - v_1}{(12 \text{ m/s}) - (-24 \text{ m/s})}$$

from which  $24 \text{ m/s} = v_2 - v_1$ . Combining this with the momentum equation found above gives  $v_2 = -4.0 \text{ m/s}$  and  $v_1 = -28 \text{ m/s}$ .

(b) In this case  $v_1 = v_2 = v$  and so the momentum equation becomes

$$3v = -36 \text{ m/s} \quad \text{or} \quad v = -12 \text{ m/s}$$

(c) Here  $e = 1$ , so

$$e = \frac{v_2 - v_1}{u_1 - u_2} \quad \text{becomes} \quad 1 = \frac{v_2 - v_1}{(12 \text{ m/s}) - (-24 \text{ m/s})}$$

from which  $v_2 - v_1 = 36 \text{ m/s}$ . Adding this to the momentum equation gives  $v_2 = 0$ . Using this value for  $v_2$  then gives  $v_1 = -36 \text{ m/s}$ .

**8.17** A ball is dropped from a height  $h$  above a tile floor and rebounds to a height of  $0.65h$ . Find the coefficient of restitution between ball and floor.

The initial and final velocities of the floor,  $u_1$  and  $v_1$ , are zero. Therefore,

$$e = \frac{v_2 - v_1}{u_1 - u_2} = -\frac{v_2}{u_2}$$

But we can write equations for the interchange of  $PE_G$  and  $KE$  both before and after the bounce:

$$mgh = \frac{1}{2}mu_2^2 \quad \text{and} \quad mg(0.65h) = \frac{1}{2}mv_2^2$$

Therefore, taking *down* as positive, we have  $u_2 = \sqrt{2gh}$  and  $v_2 = -\sqrt{1.30gh}$ . Substitution gives

$$e = \frac{\sqrt{1.30gh}}{\sqrt{2gh}} = \sqrt{0.65} = 0.81$$

**8.18**

The two balls shown in Fig. 8-4 collide and bounce off each other as shown. (a) What is the final velocity of the 500-g ball if the 800-g ball has a speed of 15 cm/s after the collision? (b) Is the collision perfectly elastic?

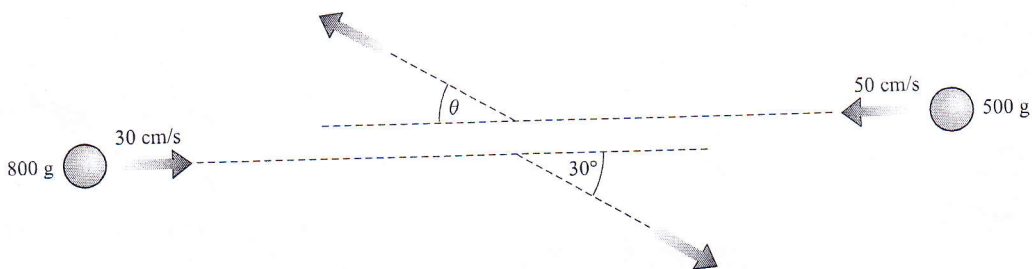

Fig. 8-4

(a) Take motion to the right as positive. From the law of conservation of momentum,

$$(\text{momentum before})_x = (\text{momentum after})_x$$

$$(0.80 \text{ kg})(0.30 \text{ m/s}) + (0.50 \text{ kg})(-0.5 \text{ m/s}) = (0.80 \text{ kg})[(0.15 \text{ m/s}) \cos 30^\circ] + (0.50 \text{ kg})v_x$$

from which  $v_x = -0.228 \text{ m/s}$ . Taking motion upward as positive,

$$(\text{momentum before})_y = (\text{momentum after})_y$$

$$0 = (0.80 \text{ kg})[-(0.15 \text{ m/s}) \sin 30^\circ] + (0.50 \text{ kg})v_y$$

from which  $v_y = 0.120$  m/s. Then

$$v = \sqrt{v_x^2 + v_y^2} = \sqrt{(-0.228 \text{ m/s})^2 + (0.120 \text{ m/s})^2} = 0.26 \text{ m/s}$$

and  $\vec{v} = 0.26$  m/s — RIGHT.

Also, for the angle  $\theta$  shown in Fig. 8-4,

$$\theta = \arctan \left( \frac{0.120}{0.228} \right) = 28^\circ$$

(b) Total KE before =  $\frac{1}{2}(0.80 \text{ kg})(0.30 \text{ m/s})^2 + \frac{1}{2}(0.50 \text{ kg})(0.50 \text{ m/s})^2 = 0.099 \text{ J}$   
 Total KE after =  $\frac{1}{2}(0.80 \text{ kg})(0.15 \text{ m/s})^2 + \frac{1}{2}(0.50 \text{ kg})(0.26 \text{ m/s})^2 = 0.026 \text{ J}$

Because KE is lost in the collision, it is not perfectly elastic.

$$e = \frac{v_2 - v_1}{u_1 - u_2}$$

- 8.19** What force is exerted on a stationary flat plate held perpendicular to a jet of water as shown in Fig. 8-5? The horizontal speed of the water is 80 cm/s, and 30 mL of the water hits the plate each second. Assume the water moves parallel to the plate after striking it. One milliliter (mL) of water has a mass of 1.00 g.

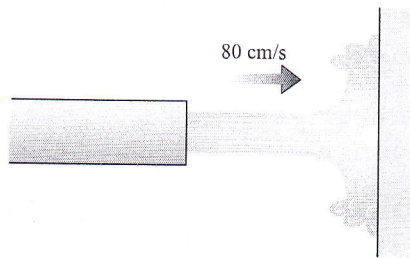

Fig. 8-5

The plate exerts an impulse on the water and changes its horizontal momentum. Taking the direction to the right as positive,

(impulse)<sub>x</sub> = change in *x*-directed momentum

$$F_x \Delta t = (mv_x)_{\text{final}} - (mv_x)_{\text{initial}}$$

Let us take  $t$  to be 1.00 s so that  $m$  will be the mass that strikes in 1.00 s, namely 30 g. Then the above equation becomes

$$F_x (1.00 \text{ s}) = (0.030 \text{ kg})(0 \text{ m/s}) - (0.030 \text{ kg})(0.80 \text{ m/s})$$

from which  $F_x = -0.024$  N. This is the force of the plate on the water. The law of action and reaction tells us that the jet exerts an equal but opposite force on the plate.

- 8.20** A rocket standing on its launch platform points straight upward. Its jet engines are activated and eject gas at a rate of 1500 kg/s. The molecules are expelled with a speed of 50 km/s. How much mass can the rocket initially have if it is slowly to rise because of the thrust of the engines?

Because the motion of the rocket itself is negligible in comparison to the speed of the expelled gas, we can assume the gas to be accelerated from rest to a speed of 50 km/s. The impulse required to provide this acceleration to a mass  $m$  of gas is

$$F \Delta t = mv_f - mv_i = m(50\,000 \text{ m/s}) - 0$$

from which

$$F = (50\,000 \text{ m/s}) \frac{m}{\Delta t}$$

But we are told that the mass ejected per second ( $m/\Delta t$ ) is 1500 kg/s, and so the force exerted on the expelled gas is

$$F = (50\,000 \text{ m/s})(1500 \text{ kg/s}) = 75 \text{ MN}$$

An equal but opposite reaction force acts on the rocket, and this is the upward thrust on the rocket. The engines can therefore support a weight of 75 MN, so the maximum mass the rocket could have is

$$M_{\text{rocket}} = \frac{\text{weight}}{g} = \frac{75 \times 10^6 \text{ N}}{9.81 \text{ m/s}^2} = 7.7 \times 10^6 \text{ kg}$$

### Supplementary Problems

- 8.21 Typically, a tennis ball hit during a serve travels away at about 51 m/s. If the ball is at rest mid-air when struck, and it has a mass of 0.058 kg, what is the change in its momentum on leaving the racket?  
*Ans.* 3.0 kg·m/s
- 8.22 During a soccer game a ball (of mass 0.425 kg), which is initially at rest, is kicked by one of the players. The ball moves off at a speed of 26 m/s. Given that the impact lasted for 8.0 ms, what was the average force exerted on the ball? *Ans.* 1.4 kN
- 8.23 A 40 000-kg freight car is coasting at a speed of 5.0 m/s along a straight track when it strikes a 30 000-kg stationary freight car and couples to it. What will be their combined speed after impact? *Ans.* 2.9 m/s
- 8.24 An empty 15 000-kg coal car is coasting on a level track at 5.00 m/s. Suddenly 5000 kg of coal is dumped into it from directly above it. The coal initially has zero horizontal velocity. Find the final speed of the car. *Ans.* 3.75 m/s.
- 8.25 Sand drops at a rate of 2000 kg/min from the bottom of a hopper onto a belt conveyer moving horizontally at 250 m/min. Determine the force needed to drive the conveyer, neglecting friction. *Ans.* 139 N
- 8.26 Two bodies of masses 8 kg and 4 kg move along the  $x$ -axis in opposite directions with velocities of 11 m/s—POSITIVE  $x$ -DIRECTION and 7 m/s—NEGATIVE  $x$ -DIRECTION, respectively. They collide and stick together. Find their velocity just after collision. *Ans.* 5 m/s—POSITIVE  $x$ -DIRECTION
- 8.27 A 1200-kg gun mounted on wheels shoots an 8.00-kg projectile with a muzzle velocity of 600 m/s at an angle of  $30.0^\circ$  above the horizontal. Find the horizontal recoil speed of the gun. *Ans.* 3.46 m/s
- 8.28 Three masses are placed on the  $y$ -axis: 2 kg at  $y = 300$  cm, 6 kg at  $y = 150$  cm, and 4 kg at  $y = -75$  cm. Find their center of mass. *Ans.*  $y = 1$  m
- 8.29 Four masses are positioned in the  $xy$ -plane as follows: 300 g at  $(x = 0, y = 2.0 \text{ m})$ , 500 g at  $(-2.0 \text{ m}, -3.0 \text{ m})$ , 700 g at  $(50 \text{ cm}, 30 \text{ cm})$ , and 900 g at  $(-80 \text{ cm}, 150 \text{ cm})$ . Find their center of mass. *Ans.*  $x = -0.57 \text{ m}, y = 0.28 \text{ m}$
- 8.30 A ball of mass  $m$  sits at the coordinate origin when it explodes into two pieces that shoot along the  $x$ -axis in opposite directions. When one of the pieces (which has mass  $0.270m$ ) is at  $x = 70$  cm, where is the other piece? (*Hint:* What happens to the mass center?) *Ans.* at  $x = -26$  cm